



User's Manual

ESC/POS PRINTER

MODEL **EP-1000**



CONTENTS

1. GENERAL OUTLINE	9
1.1 Features	9
1.2 Unpacking	10
1.3 Basic Specifications	11
2. EXPLANATION OF PRINTER PARTS	12
2.1 Top View	12
2.2 Bottom View	12
3. PREPARATION	13
3.1 Connecting the AC Adapter and AC Power Cord	13
3.2 Connecting Interface Cables	14
3.3 Connecting the Cash Drawer or External Display	14
3.4 Adjusting the Paper Near-end Sensor	15
3.5 Partition for 58-mm Wide Paper Roll	16
3.6 Setting DIP Switches	17
4. MAINTENANCE AND TROUBLESHOOTING	18
4.1 Setting/Replacing Paper Rolls	18
4.2 Removing Jammed Paper	20
4.3 Cleaning the Print Head	20
4.4 Self-test printing	21
4.5 Operation Panel and Error Indication	22
4.6 Specifications of Drawer Kick-Out Connector & External Display	24
4.7 Specifications of the power Connector	25
5. COMMAND LIST	26
6. DETAILED DESCRIPTION	28

THE INFORMATION IN THIS DOCUMENT CANNOT BE REPRODUCED IN ANY
MECHANICAL, ELECTRICAL OR ELECTRONIC WAY AND UNDER ANY
CIRCUMSTANCES WITHOUT THE WRITTEN CONSENT FROM DATECS LTD.
Sofia 1784 - BULGARIA, tel: +359 2 974 00 55, fax: +359 2 974 11 00,
e-mail: sales@datecs.bg <http://www.datecs.bg>
VERSION 1.04 / december 2007 / EN

PRECAUTIONS FOR HANDLING

Observe the following precautions to use the EP-1000 Printer correctly and avoid troubles from occurring.

- Do not use any other power supply than the specified AC adapter.
- Do not allow the printer to start printing when there is no recording paper installed.
- Be careful not to drop foreign substances, such as paper clips, pins or screws, into the printer.
- Do not spill any liquid on the printer, or spray it with any chemical containing liquid.
- Do not stamp on, drop, hit, or impart any strong shock to the printer.
- Never use any pointed object such as a pen, to operate the controls on the operation panel.
- Do not use cellophane tape to join the ends of paper to allow continuous printing.
- Never pull the end of the paper installed forcibly with the printer cover left closed.
- When opening/closing the cover, be careful that the paper does not get caught.

To prevent injuries and associated damages:

- Do not touch the printing part of the print head.
- While the printer is turned on, never touch the moving parts inside, such as the cutter, gears, and electrical parts.
- Be careful to avoid bodily injuries or damaging other objects with edges of sheet metal parts.
- Should any abnormal condition occur while the printer is operating, stop it immediately and disconnect the power plug from the wall outlet.
- When opening/closing the cover, and so on, be careful not to catch your hand or finger on the equipment.
- Do not try to disassemble and repair the printer on your own.



In the position indicated below, a label is provided to alert your attention. Read the cautionary information on it, and handle the printer properly.

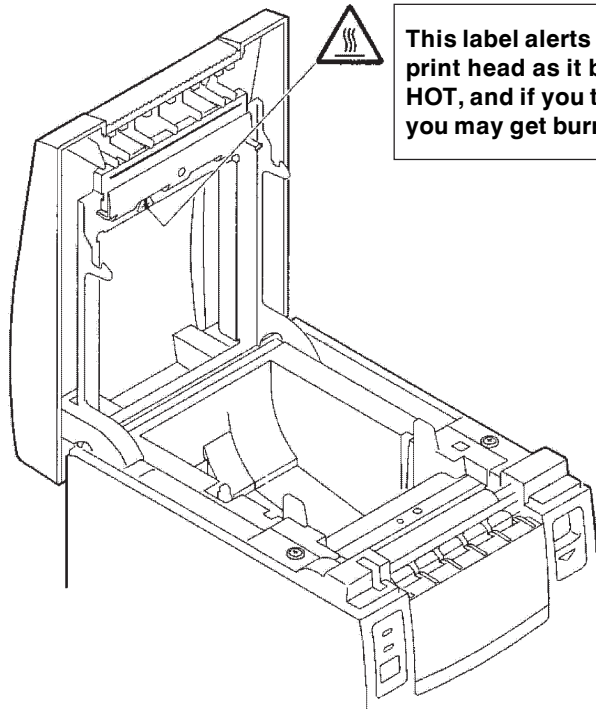

This label alerts you to the print head as it becomes HOT, and if you touch it, you may get burnt.



HOT AREA:

Be careful not to touch this area to avoid burns as it becomes HOT.



DAILY MAINTENANCE

- Prior to start maintenance work, be sure to turn off the printer.
- When cleaning the platen, use a cotton swab applied with ethyl alcohol and wipe off stains.

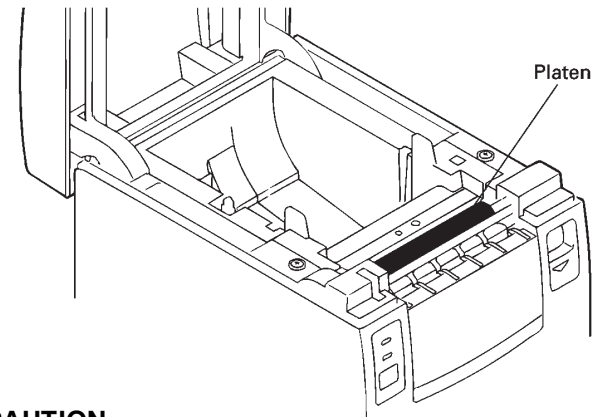

CAUTION

Avoid cleaning the print head immediately after printing is finished. The print head is HOT.

- Use a dry soft cloth to wipe off stains and dust from the surfaces of the printer covers.
- When wiping clean heavily stained areas, use a cloth which should be dipped in water and then wrung strongly. Never use organic solvents, such as alcohol, thinner, trichlene, benzene, ketone, or chemical dusters.
- If the printer is contaminated with paper dust, use a soft brush to wipe off.

DAILY MAINTENANCE

Cleaning the print head

- 1** Turn off the power of the printer.
- 2** Open the printer cover.
- 3** Using a gauze impregnated with a small amount of alcohol, wipe off stains and dust on the heat-emitting surface of the head.

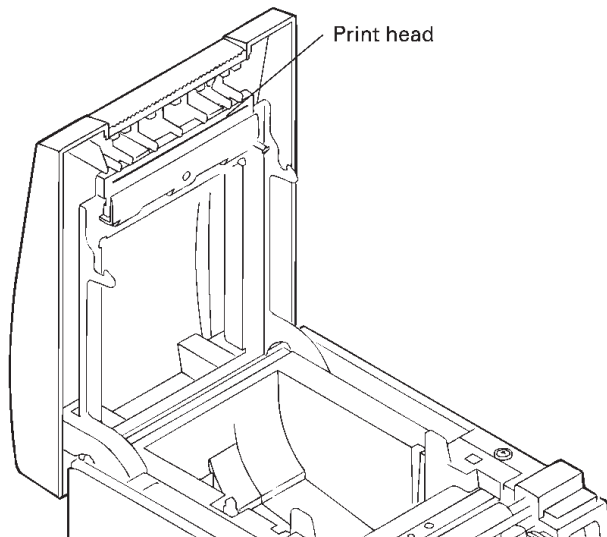

CAUTION

Avoid cleaning the print head immediately after printing is finished. The print head is HOT. Do not touch the heat-emitting surface of the head with bare hands or metal objects.

1. GENERAL OUTLINE

This manual describes the general outline, preparations, maintenance & troubleshooting of the ESC/POS printer EP-1000. Also it includes command list and detailed description of the commands.

1.1 Features

The EP-1000 is a line thermal printer which can be used in different applications like communication terminals, ESC/POS terminals & networks and more.

- ◆ ESC/POS printer
- ◆ Compact design
- ◆ Low-noise printing
- ◆ Use of 80 mm - or 58 mm wide paper is available.
- ◆ Auto cutter mechanism provided as a standard unit
- ◆ Built-in input buffer
- ◆ Bar code printing
- ◆ High-speed printing at 100 mm/s max.
- ◆ Built-in Interface for External Display
- ◆ Power supply - AC adaptor
- ◆ Built-in Drawer Kick-out interface

1.2 Unpacking

When unpacking the printer, confirm that the following are provided:

- ◆ Printer 1 unit
- ◆ Partition (For 58 mm wide paper roll) 1 piece
- ◆ AC adapter 1 piece
- ◆ AC power cord 1 piece
- ◆ Sample paper roll (Paper width 80 mm) 1 piece
- ◆ User's manual (This book) 1 piece

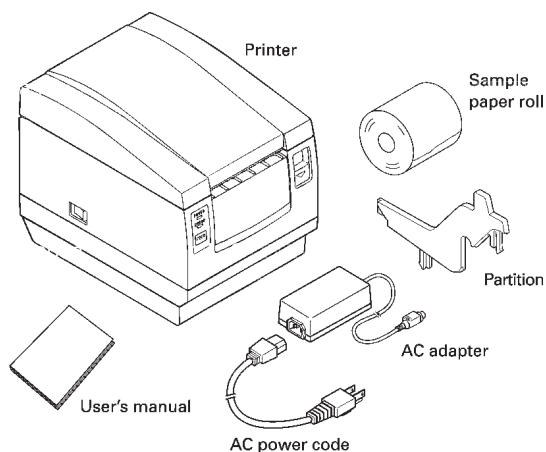

CAUTION

- Install the printer on a flat, sturdy table.
- Do not install the printer near a heater or in a place exposed to direct sunlight.
- Do not use the printer in a high-temperature, high-humidity, or heavily contaminated environment.
- Do not use the printer in an environment where condensation may occur. If condensation should occur, leave the power turned off until condensation evaporates completely.

1.3 Basic Specifications

Item	Specifications
Printing Method	Line thermal print method
Printer	KF2003-GD30C
Printing Width	52mm, 416 dots (76mm, 608dots)
Dot Density	8 dots/mm (Horizontal/Vertical)
Paper Feed Pitch	0.125mm
Printing Speed	Max speed 100 mm/sec
Number of print columns	50 / 34 columns (font A) 66 / 45 columns (font B)
Character size	Font A : 12 x 24 Font B : 9 x 16
Bar Code Types	Code39, Code93, EAN13, EAN8, UPC-A, UPC-E, Interleaved 2 of 5, Codabar, Code 128
Paper	Thermal roll paper 58 mm or 80 mm, Ø 60 mm or 83 mm
Paper Thickness	60 - 65 μm
Interface	RS-232 Interface, type RS-232C, max 115200bps
MCU	Winbond (W77E58P-40) - 8 bits microcontroller
Input Buffer	32K bytes
Power Consumption	50W max
Adaptor	Model: 32AD Input: AC 100 - 240V , 1.3A , 50/60Hz Output: DC 24V, 2A
Indication	Green LED - Power Red LED - Error (cutter error, head overheat, open cover)
Weight	Approx. 2 kg
External Dimensions	190(W)mm X 145(D)mm X 114(H)mm
Operating Temperature and Humidity	5~40°C 35~85%RH
Storage Temperature and Humidity	-10~60°C 10~90%RH
Reliability	Print head life: 100 million pulses and 100km wear resistance Printer Mechanism: 10 million lines Auto Cutter Life: 500 000 cuts

2. EXPLANATION OF PRINTER PARTS

2.1 Top View

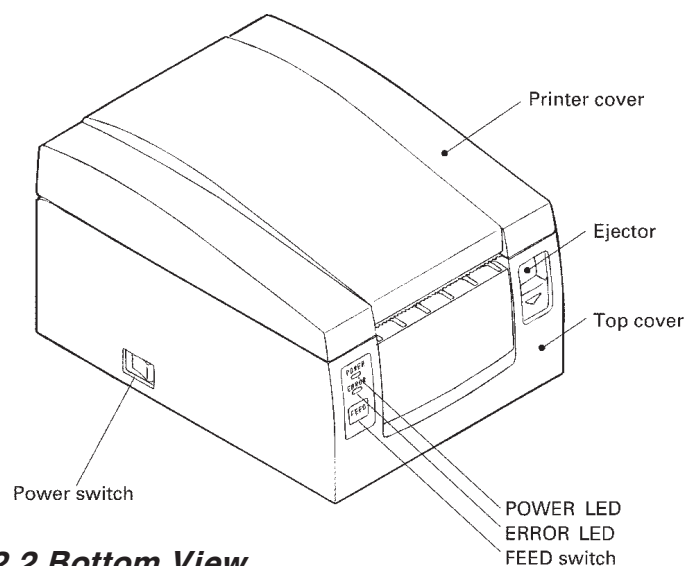

2.2 Bottom View

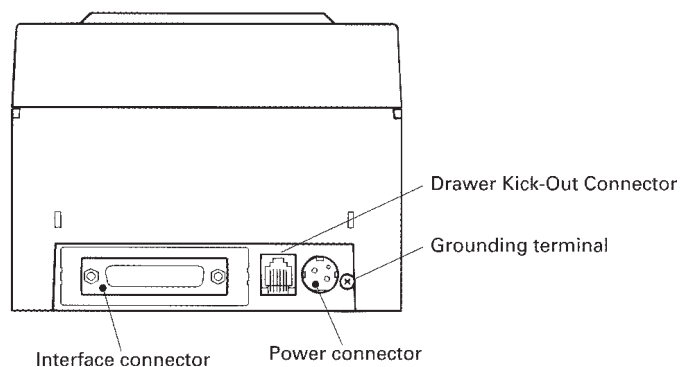

3. PREPARATION

3.1 Connecting the AC Adapter and AC Power Cord

- 1 Turn off the printer power.
- 2 For the AC adapter type only: With the flat side of the AC adapter's cable connector facing upward, insert the cable connector into the power connector on the back side of the printer.
- 3 Connect the AC power cord to the AC adapter, and insert the AC-power-cord plug into a suitable wall outlet.

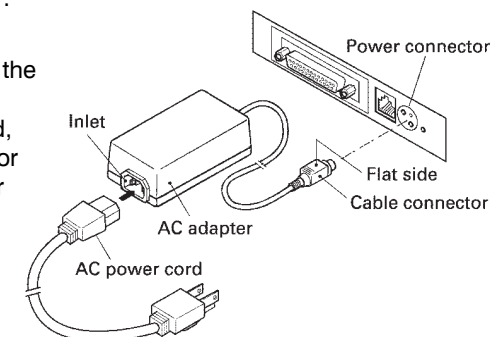

⚠ CAUTION

- Do not use any AC adapter other than specified.
- When connecting or disconnecting the cable connector of the AC adapter, always pull on the connector, not on the cable.
- The AC power cord should be connected to a wall outlet separated from others used by other equipment which tend to emit noise.
- Avoid pulling on the power cord, or the cord may be damaged or broken, causing a fire, electric shock.
- When the thunder rumbles nearby, disconnect the AC power cord from the wall outlet; otherwise, a thunderbolt may cause a fire or electric shock.
- Avoid placing the power cord near a heating device; otherwise, the cover of the cord may melt, causing a fire or electric shock.
- When you are not going to use the printer for a long period of time, disconnect the AC power cord from the wall outlet for safety.

3.2 Connecting Interface Cables

- 1 Turn off the power of the printer. (As well as the host computer connected)
- 2 Orienting the interface cable terminal correctly, insert it into the interface connector.
- 3 Connect the other end of the interface cable to the host computer.

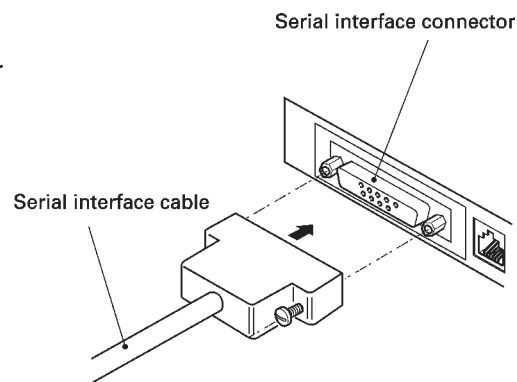

3.3 Connecting the Cash Drawer or External Display

- 1 Turn off the power of the printer.
- 2 Orienting the Drawer Kick-Out/External Display Cable Connector correctly, insert it into the Drawer Kick-Out/ External Display Connector on the back of the printer.
- 3 Fasten the ground wire to the ground connector on the printer with a screw.

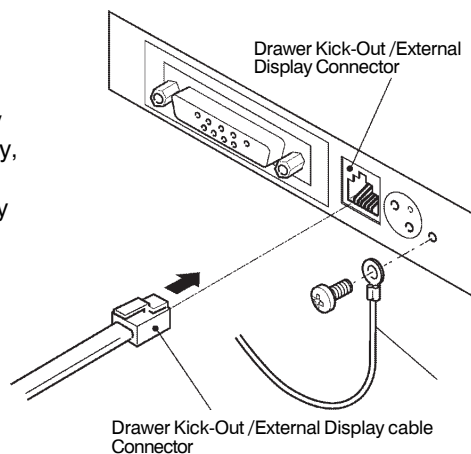

CAUTION

Do not connect any other device than the specified drawer (Solenoid) to the Drawer Kick-Out Connector. (Do not connect a telephone line either.)

3.4 Adjusting the Paper Near-end Sensor

- 1 Open the printer cover.
- 2 Push the sensor knob in the direction of arrow 1 to disengage its claw (Or unlock the sensor unit), and then adjust the sensor unit to a desired paper remaining position within the range shown by arrow 2.
- 3 The following table shows the relationship between adjustment positions and levels of paper roll remaining. (A rough guide)

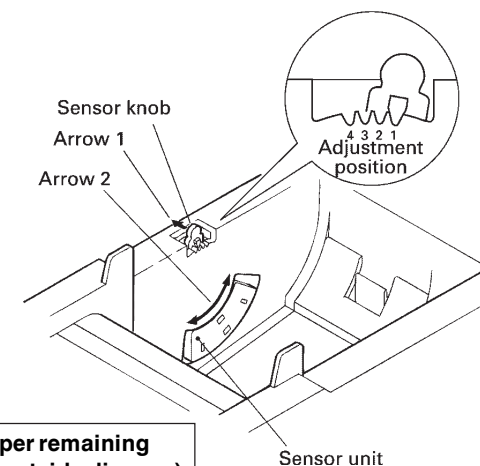

Adjustment position	Level of paper remaining (Paper roll outside dia. mm)
1	φ18
2	φ21
3	φ24
4	φ27

* When specified paper rolls are used.

CAUTION

Use the level of paper remaining (Paper-roll outside diameter) just as a guide as it varies depending on the particular printer and paper rolls used.

3.5 Partition for 58-mm Wide Paper Roll

- 1 Turn off the power of the printer.
- 2 Open the printer cover.
- 3 Fit the partition supplied into the position shown.

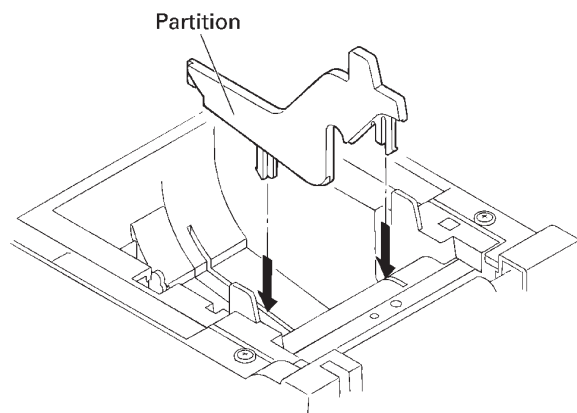

3.6 Setting DIP Switches

- 1 Turn off the power of the printer.
- 2 Open the printer cover.
- 3 Remove the paper roll.
- 4 While pulling the tab of the DIPswitch cover (To unlock it), lift out the cover.

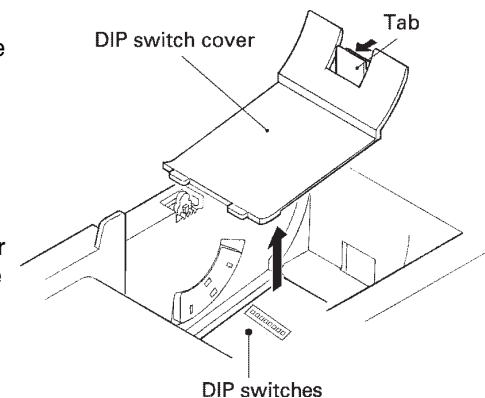

Select Baud Rate			
Sw1	Sw2	Sw3	Baud Rate (bps)
OFF	OFF	OFF	1200
ON	OFF	OFF	2400
OFF	ON	OFF	4800
ON	ON	OFF	9600
OFF	OFF	ON	19200
ON	OFF	ON	38400
OFF	ON	ON	57600
ON	ON	ON	115200

Switch	OFF	ON
Sw4	Hardware protocol	XON / XOFF protocol
Sw5	Standard commands	Extended commands
Sw6	Enables ESC t command	Disables ESC t command
Sw7	Disable the auto-cutter	Enable auto-cutter
Sw8	Narrow paper mode (57 mm)	Wide paper mode (80 □□)

4. MAINTENANCE AND TROUBLESHOOTING

4.1 Setting/Replacing Paper Rolls

- 1 Turn on the printer.
- 2 Push the ejector in the direction shown to unlock the printer cover.
- 3 Placing your hands on both sides of the printer cover, open it until it comes to a stop.

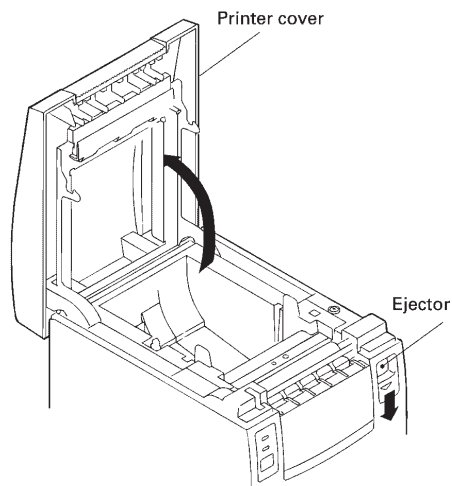

- 4 Check the winding direction of the paper roll, and then place it into the paper roll holder correctly.
- 5 With the end of the paper approx. 5 cm out of the case of the printer, close the printer cover. Push lightly on the printer cover until a „click“ is heard.

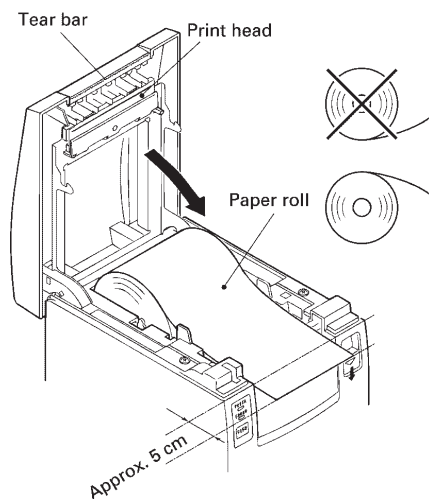

- 6 Remove an excess length of paper with the tear bar. (Manual cutter)

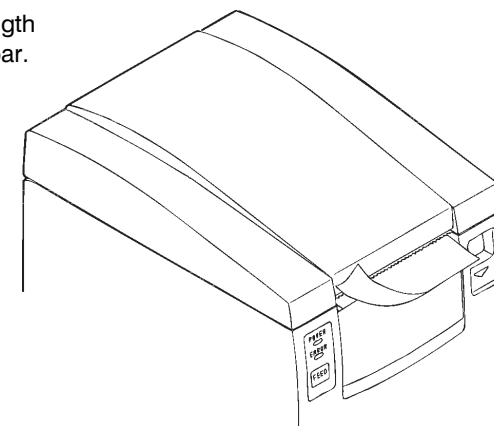

⚠ CAUTION

- Always use the specified types of paper roll.
- Use of other types of paper roll may not be able to guarantee the specified print quality or service life of the printer.
- When opening the printer cover, do not apply an excess force to it beyond its stop position.
- The print head has become hot immediately after printing. Do not touch it with your hand.
- During printing, do not open the printer cover.
- During printing, do not hold the end of the paper printed and ejected, or paper jam may occur.

4.2 Removing Jammed Paper

- 1 Turn off the power of the printer.
- 2 Open the printer cover.
- 3 Remove the paper jam including any paper chips remaining. (Also take out the paper roll from the holder.)
- 4 Close the printer cover.
- 5 Turn on the printer. The auto cutter mechanism is initialized and the alarm is cleared.

4.3 Cleaning the Print Head

- 1 Turn off the power of the printer.
- 2 Open the printer cover.
- 3 Wipe off stains, such as dust and the like, on the heating element of the head using a cotton swab impregnated with ethyl alcohol.

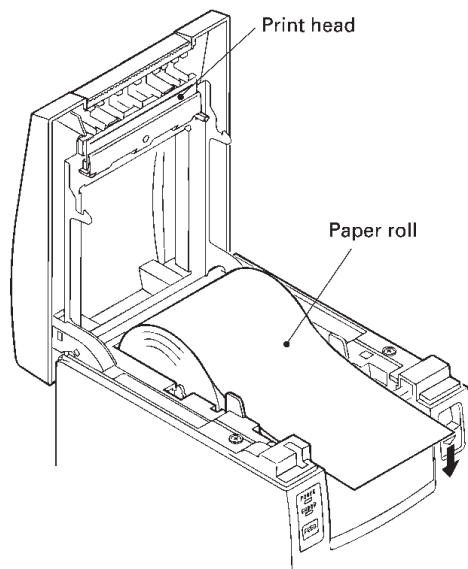

4.4 Self-test printing

If EP-1000 is already switched on - Turn the printer power off. Hold the FEED switch, then turn the printer power on. After about 1 second, the printer starts self-test printing - some diagnostic information for model name, DIP switches setting, baud rate, firmware version and more.

The image shows a sample of self-test printing output from the DATECS EP-1000 printer. The output is organized into sections with annotations on the right side:

- Font size (symbol per line):** The first section shows the printer's model and version, followed by two internal fonts (9x16 & 12x24) and two loadable fonts (9x16 & 12x24). It specifies the number of symbols per line for each font.
- Font style:** The second section shows the words 'Normal', 'Bold', 'UnderLine', and 'Italic' in their respective styles. Below this, it shows characters rotated by 180 degrees.
- Symbols:** The third section is titled 'Different sizes chars' and displays a wide range of characters in various sizes, including Latin, Cyrillic, and special characters.
- Barcode:** The fourth section is titled 'Supported bar codes:' and lists EAN13, EAN8, UPCA, UPCE, Code39, Code93, 2 of 5 interleaved, Codabar, Code128, and PDF417. It includes two barcode examples with their corresponding numbers.
- Some information (FIRMWARE VERSION, t^o by printing Head, configuration DIP switches, baud rate, protocol,):** The final section is titled 'Downloadable graphics' and lists various printer settings: Intensity (188 %), Temperature (25 C), Country (U. S. A.), Code Page (CP858 BUL), ESC t (Enabled), Speed (115200 bps), Protocol (Hardware), and DIP Sw. (1 2 3 4 5 6 7 8).

4.5 Operation Panel and Error Indication

4.5.1 OPERATION PANEL

◆ POWER LED (Green)

Lights when the power is turned on.

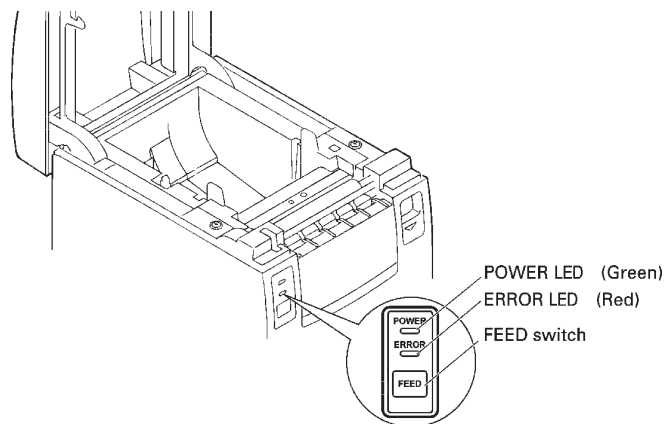

◆ ERROR LED (Red)

Lights or blinks to show different error status.

◆ Feed switch

Pressing this switch briefly causes one line of paper feeding. Holding down the switch causes continuous paper feeding.

4.5.2 ERROR INDICATION

◆ Paper end

Paper empty is detected in two steps: paper near-end and paper end. It causes the ERROR LED blinks 1 time per sec.. If paper end is detected, refill the paper.

◆ Paper cover open

During printing, do not open the paper cover. If you open the paper cover accidentally, the ERROR LED lights. Confirm the paper and close the over. Printing resumes automatically.

◆ Thermal head overheat

When you print dense characters or dark image, the head temperature rises. If the head temperature exceeds a specified level, the printer stops printing operation and waits till the head temperature is lowered. During waiting, the POWER LED blinks. When the head temperature is lowered, printing resumes automatically.

Status	Power LED	ERROR LED
Paper end	Lights	Blinks 1 time per sec.
Paper near end	Lights	Blinks 1 time per sec.
Cover open error	Lights	Lights
Head Overheat error	Blinks	Not Lights

4.6 Specifications of Drawer Kick-Out Connector & External Display

4.6.1 ELECTRICAL CHARACTERISTICS

- Drive voltage: DC 24 V
- Drive current: 1 A max
- SW signal: Signal level „L“ = 0 to 0.5 V
„H“ = 3 to 5 V

4.6.2 CONNECTOR PIN CONFIGURATION

No.	Signal	Definition
1	VDR	Drawer drive power supply
2	GND	Common ground
3	GND	Common ground
4	TXD Display	Data to external display
5	DRAWER	Drawer drive signal (output)
6	□pen Drw	Drawer open signal (input)

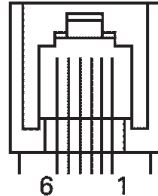

Connector used: 6P6C

4.6.3 DRIVE CIRCUIT

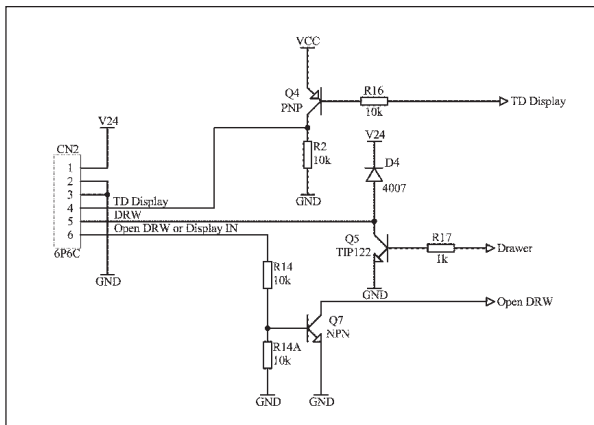

4.7 Specifications of the power Connector

The following shows the power connector from the dedicated AC adapter.

Pin configuration of Power connector (Pin number and function)

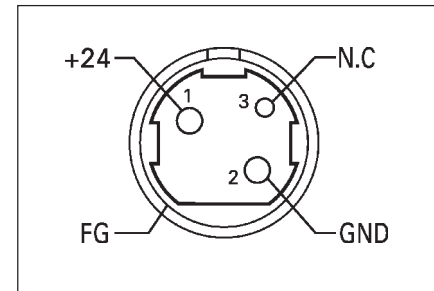

Power connector: TCS7960-53-2010 (Hosiden)

5. Command List

1	BEL	Sounds the beeper	07H
2	HT	Horizontal tab command	09H
3	LF	Printing and paper feed	0AH
4	CR	Print command	0DH
5	ESC RS	Sounds the beeper	1BH 1EH
6	ESC SP	Setting the right space amount of the character	1BH 20H n
7	ESC #	Setting the Euro symbol position	1BH 23H n
8	ESC \$	Specifying the absolute positions	1BH 24H n1 n2
9	ESC %	Selecting user character set	1BH 25H n
10	ESC &	Define user characters	1BH 26H m n1 n2
11	ESC !	Collective specifying printing mode	1BH 21H n
12	ESC *	Specifying the bit image mode	1BH 2AH m n1n2[d]k
13	ESC -	Specifying/cancelling underline	1BH 2DH n
14	ESC .	Self test / demo	
15	ESC ,	Printing diagnostic information	1BH 54H
16	ESC 2	Specifying 1/6-inch line feed rate	1BH 32H
17	ESC 3	Setting line feed rate of minimum pitch	1BH 33H n
18	ESC 8	Temporary store current print settings	1BH 38H
19	ESC 9	Restore saved printer settings	1BH 39H
20	ESC =	Data input control	1BH 3DH n
21	ESC >	Set Factory Defaults	1BH 3EH n
22	ESC @	Initializing the Printer	1BH 40H
23	ESC D	Setting horizontal tab position	1BH 44H [n]k 00H
24	ESC E	Specifying/cancelling highlighting	1BH 45H n
25	ESC G	Specifying/cancelling double printing	1BH 47H n
26	ESC I	Specifying/cancelling italic printing	1BH 49H n
27	ESC J	Printing and feeding paper n/203 inch	1BH 4AH n
28	ESC M	Selecting character font A or B	1BH 4DH n
29	ESC R	Setting the international character set	
30	ESC V	Specifying/canceling 90°-right-turned characters	1BH 56H n
31	ESC X	Select maximal printing speed	
32	ESC Y	Selecting intensity level	1BH 59H n

33	ESC Z	Transmits identification string	1BH 5AH
34	ESC \	Specifying the relative positions	1BH 5CH n1 n2
35	ESC _	Restore factory settings	1BH 5FH
36	ESC ^	Transmits current battery voltage and the print head temperature	1BH 60H
37	ESC a	Aligning the characters	1BH 61H n
38	ESC c5	Enabling/disabling the panel switches	1BH 63H 35H n
39	ESC d	Printing and feeding the paper by n lines	1BH 64H n
40	ESC i	Cutting the paper	
41	ESC m	Cutting the paper	
42	ESC p	Generating a drawer-kick pulse	
43	ESC t	Selecting the character code table	
44	ESC v	Transmitting the printer status	1BH 76H n
45	ESC x	Reversing the print direction	1BH 78H n
46	ESC {	Specifying/canceling the inverted characters	1BH 7BH n
47	GS (A	Printing a self-test	
48	GS B	Specifying/canceling the black/white inverted printing	
49	GS L	Setting the left margin	1DH 4CH n1 n2
50	GS V	Cutting the paper	
51	GS k	Printing the barcode	1DH 6BH n [d]
52	GS w	Selecting the horizontal size (scale factor) of barcode	1DH 77H n
53	GS h	Selecting the height of the barcode	1DH 68H n
54	GS H	Selecting of print position of HRI code	1DH 48H n
55	GS f	Selecting the font of HRI code	1DH 66H n
56	GS p	Setting barcode PDF-417 parameters	1DH 70H
57	GS v 0	Printing of raster bit image	
58	GS *	Defining the downloaded bit image	1DH2An1n2[d]n1xn2
59	GS /	Printing the downloaded bit image	1DH 2FH m
60	GS :	Starting/ending macro definition	1DH 3AH
61	GS ^	Executing the macro	1DH 5EH n1 n2 n3
62	FS p	Printing the downloaded NV bit image	1CH 70H n m
63	FS q	Defining the downloaded NV bit image	1CH 71H n xL xH yL yH [d]

6. Detailed Description

1. BEL

Sounds the beeper

[Code] **[07h]**

[Outline] Sounds the beeper.

2. HT

Horizontal Tab Command

[Code] **[09h]**

[Outline] Shifts the printing position to the next horizontal tab position.

- Ignored when the next horizontal tab position has not been set.
- The horizontal tab position is set by ESC D.
- Initial setting of the horizontal tab position is each 8 characters in 9th, 17th, 25th, columns.

[See Also] ESCD

3. LF

Printing and Paper Feed Command

[Code] **[0Ah]**

[Outline] Prints data inside the input buffer and feeds lines based on the line feed amount having been set.
The head of the line becomes the next print starting position.

[See Also] ESC2, ESC3

4. CR

Print Command

[Code] **[0Dh]**

This command is ignored.

5. ESC RS

Sounds the beeper

[Code] **[1Bh] + [1Eh]**

[Outline] Sounds the beeper.

6. ESC SP n

Setting the right space amount of the character

[Code] **[1Bh] + [20h] + n**

[Range] {0 <= n <= 20h}

[Outline] The rightward space amount is set in dot unit (1/203 inch unit).

[Caution] The rightward space amount in double wide mode is made double of the set volume.

[Default] n = 0

7. ESC # n

Setting the Euro symbol position

[Code] **[1Bh] + [23h] + n**

[Range] {0 <= n <= FFh}

[Outline] This command is provided because most of the old OEM/DOS code ... pages do not have the euro symbol mapped. This command shows the direct position of the euro symbol in the code table. If n is given value less than 20h the Euro symbol will not be shown.

[Caution] When the code page is changed the Euro symbol position is cleared! . The Euro symbol position must be re-entered any time the code page is changed (see below).

Any symbol of the code table could be remapped, with no restrictions. The user must take care not to remap some of the most commonly used symbols.

Some of the code pages supported by the printer (Windows code pages) include the Euro symbol, using the command in such case will result in Euro symbol appearing twice in the code table.

Code pages 20, 21, 22 and 23 (CP858, CP852 + Euro, CP808 and CP857 + Euro) are not hard-coded code pages, i.e. they do not have the Euro Symbol built in. They are produced by giving the Euro symbol position

the proper value. If the command is used with some of these pages the Euro symbol position will be changed, i.e. it will not appear twice. The command ESC > stores the Euro symbol position for further use as a default value.

[Default] n = 0 (Not selected)
 if code page = 20 (CP858), n = D5h;
 if code page = 21 (CP852 + Euro), n = AAh;
 if code page = 22 (CP808), n = F2h;
 if code page = 23 (CP857 + Euro), n = D5h.

8. ESC \$ n1 n2

Specifying the Absolute Positions

[Code] **[1Bh] + [24h] + n1 + n2**

[Range] {0 <= n1 <= FFh}
 {0 <= n2 <= 2}
 {0 <= n1+n2*256 <= 415} – if narrow paper is used
 {0 <= n1+n2*256 <= 575} – if wide paper is used

[Outline] The printing start position is specified in the number of dots (1/203 inch unit) from the beginning of line.

- The number of dots is divided by 256, whose quotient is taken as n2 and the residual as n1.
- Therefore, the printing start position is equal to n1 + n2 x 256 from the beginning of line..

[Caution] Specifying beyond the line end is ignored.

[Default] The initial value is not specified.

[See Also] ESC\

9. ESC % n

Select/cancel user defined characters

[Code] **[1Bh] + [25h] + n**

- Only bit 0 of n is defined
 Value 0: Selected
 Value 1: Not selected

[See also] ESC&

10. ESC & s n1 n2 [a [d] s x a] k

ESC & m n1 n2 [d] k

Define user characters

There are two different types of this command selected by switch 5's position.

If switch 5 is OFF:

[Code] **[1Bh] + [26h] + s + n + m + [a₁ + D₁] + ... + [a_{m-n+1} + D_{m-n+1}]**

[Range] {s = 3}
 {20h <= n <= FFh}
 {n <= m <= FFh}
 {0 <= a <= 12}
 {0 <= D_i <= FFh}

[Outline] Defines a group of downloaded characters where:
 „s“ is the number of bytes in vertical direction – always three.
 „n“ indicates the start character code and „m“ indicates the end character code. To define only one character set n=m.
 „a“ is the number of dots in horizontal direction.
 „D_i“ is the data to be defined. The number of data for each symbol is s x a. Each symbol defines with three bytes of data in vertical direction followed by the next three bytes that define the next one-dot column, etc. The downloaded font is cleared by ESC @ and ESC _ commands and when the printer is switched off.

[Default] The default downloaded font is equal to the default character set. However the downloaded font is not reset when the code page is changed, thus it remains the same as the previous code page.

If switch 5 is ON:

[Code] **[1Bh] + [26h] + a + n1 + n2 + D₁ + ... + D_{(m-n+1)k}**

[Range] {m = 0-3 Subcommand}
 {20h <= n1 <= FFh}
 {n1 <= n2 <= FFh}
 {k = (n2-n1+1)*48 for m=2 and k = (n2-n1+1)*16 for m=3}

[Outline] Defines a group of user characters.
m=0: Copy internal character set A to user character set A (Parameters n1, n2 and d are omitted)
m=1: Copy internal character set B to user character set B (Parameters n1, n2 and d are omitted)

m=2: Define character group with ASCII codes between $\geq n1$ and $\leq n2$ for character set A (12x24). Every character is 48 bytes, two bytes for each line. Only the first nibble of the second byte is used.

m=3: Define character group with ASCII codes between $\geq n1$ and $\leq n2$ for character set B (9x16). Every character is 16 bytes.

n1 is the ASCII code of the first and **n2** is the ASCII code of the last of $(n2-n1+1)$ consecutive symbols. To define a single symbol $n1=n2$.

d is the data that defines the symbols. Every Font A symbol consists of 48 bytes while every Font B symbol consists of 16 bytes.

A Font A symbol is defined left to right, top to bottom, two bytes for each horizontal line, as only the four most significant bits of the second byte are used. Every bit denotes one dot. A bit set to '1' means black dot. The most significant bit is the starting.

Every horizontal line of Font B symbol consists of one byte, as the ninth point is always white. The most significant bit is the starting.

The user-defined characters are kept after printer off.

[See Also] ESC%

11. ESC ! n

Collective Specifying Printing Mode

[Code] **[1Bh] + [21h] + n**

[Range] {0 <= n <= FFh}

[Outline] Printing mode is assigned. Each n bit indicates the following:

Bit	Function	Value 0	Value 1
0	Character Font	Font A	Font B
1	Undefined		
2	Undefined		
3	High-lighting	Canceled	Specified
4	Double height	Canceled	Specified
5	Double width	Canceled	Specified
6	Undefined		
7	Underline	Canceled	Specified

- [Caution]
- With double height and double width being specified simultaneously, double wide and double high characters are consisted.
 - An underline is attached to the full character width, which, however, is not attached to the part having been skipped by the horizontal tab. Neither is it attached to 90°-right-turned characters.
 - The underline width is as having been specified by <ESC - >. (The default setting is 1 dot width)
 - In case that double wide character and normal character exist in same one line, the layout of underline is consistent one.

[Default] n = 0

[See Also] ESC E, ESC -

12. ESC * m n1 n2 [d] k

Specifying the Bit Image Mode

[Code] **[1Bh] + [2Ah] + m + n1 + n2 + D₁ + ... + D_k**

[Range] {m = 0, 1, 32, 33 bit image mode (See the table below.)}

{0 <= n1 <= FFh}

{0 <= n2 <= 3}

{0 <= d <= FFh}

{k = n1 + 256 X n2 (m = 0, 1)}

{k = (n1+256 X n2) X 3} (m = 32, 33)

[Outline] According to the number of dots specified in n1, n2, specify the bit image of mode m.

- The total number of dots printed in the bit image is equal to $n1 + (256 \times n2)$.
- When bit image data have been input in excess of dot position of one line (384 dots), the excess data are discarded.
- **d** is bit image data, the bits subject to printing are taken as "1" and those not as "0".
- The bit image modes specified by **m** are shown as follows:

		Vertical Direction		Horizontal Direction	
m	Mode	Dots	Dot Density	Dot Density	Max. Dots
0	8-dot single density	8	67 DPI	101 DPI	192
1	8-dot double density	8	67 DPI	203 DPI	384
32	24-dot single density	24	203 DPI	101 DPI	192
33	24-dot double density	24	203 DPI	203 DPI	384

- [Caution] • When the values set in m (bit image mode) are out of the above range, the data following after n1 is processed as normal printing data.
- After completion of bit image printing, printer returns to normal data processing mode.

The command has another variant with four new modes:

ESC * m n[d] k

ESC * m n a f [d] k

Specifying the Bit Image Mode (Sending graphics data horizontally)

[Code] **[1Bh] + [2Ah] + m + n + { a + [00h] } + D₁ + ... + D_k**

[Range] {m = 16, 17, 18, 20 bit image mode }
 {0 <= n <= 40h}
 {0 <= d <= FFh}
 {k = n * 24 * 48} (m = 16)
 {k = n * 24 * 48} (m = 17) {After decompression}
 {k = n * h * 48} (m = 18) {After decompression}
 {k = n * 24 * 48} (m = 20) After decompression
 {0 <= a <= 24 (Used only for mode 18.)}
 {f = 0 (Used only for mode 18.)}

[Outline] In these graphics modes is sent a graphics block with variable width n*8 dots and height 24 dots for modes 16,17 and a dots for mode 18. In mode 17 data is compressed, and the bytes count specified is before the compression. In mode 16 the same data is without compression. Mode 20 is similar to mode 17, but every byte is mirrored before putting in the print buffer (bits 0 and 7, 1 and 6, 2 and 5, 3 and 4 change places). All modes are high resolution (203 x 203 DPI).

- When bit image data have been input in excess of dot position of one line (384 dots) , the excess data are discarded.
- **d** is bit image data, the bits subject to printing are taken as "1" and those not as "0".

- [Caution] • When the values set in m (bit image mode) are out of the above range, the data following after n is processed as normal printing data.
- After completion of bit image printing, printer returns to normal data processing mode.

[Compression procedure for mode 17 and 18]

A simple RLE encoding like this in PCX files is used. If two most significant bits of the byte are set, the 6 LSB contain a repeat counter (1-63), and the next byte contains the data to be repeated. A single data byte with 2 MSB set must be sent as two bytes.

13. ESC – n

Specifying/ Canceling Underline

[Code] **[1Bh] + [2Dh] + n**

[Range] {0 <= n <= 2}

[Outline] Specifying/canceling an underline.

- Types of underlines by n value are shown below:

- 0** Canceling an underline.
- 1** Specifying an underline for 1-dot width.
- 2** Specifying an underline for 2-dots width.

- [Caution] • An underline is attached to the full character width. It is, however, not attached to the part having been skipped by horizontal tab command.
- An underline is not attached to a 90°- right-turned characters.

[See Also] ESC!

14. ESC .

Selftest

[Code] **[1Bh] + [2Eh]**

[Outline] Prints character table, character samples with different attributes and diagnostic information.

[See also] ESC,

15. ESC ,

Printing diagnostic information

[Code] **[1Bh] + [2Ch]**

[Outline] Printing current intensity level, temperature, code tables, communication mode, protocol and serial port speed if a serial communication board is installed.

[See also] ESC.

16. ESC 2

Specifying 1/6-inch line feed rate

[Code] **[1Bh] + [32h]**

[Outline] The line feed rate per line is specified by 1/6 inch.

17. ESC 3 n

Setting line feed rate of minimum pitch

[Code] **[1Bh] + [33h] + n**

[Range] {0 <= n <= FFh}

[Outline] The line feed rate per line is specified by n/203 inch.

[Default] The initial value is n = 34 (1/6 inch) (22H), being 4.23 mm line feed rate.

18. ESC 8

Temporary store current print settings

[Code] **[1Bh] + [38h]**

[Outline] Use command 'ESC 9' to restore the parameters. The parameters stored are:

double height/width symbols, rotated by 90 degrees symbols, font size, underline, emphasize, italic style, downloaded font active, rotated by 180 degrees symbols, black and white inverse symbols, reverse print direction (from right to left), Chinese/Arabic code table selected (only in the Chinese/Arabic printer version), print density, printing speed, left margin, printing width, line height, intercharacter space, country, code page, Euro symbol position, barcode width, barcode height, barcode HRI position.

[Caution] The printer uses this command when printing full and short self-tests. So if a self-test is printed, the printer will store the print settings active at the time the printing starts.

19. ESC 9

Restore the previously saved settings

[Code] **[1Bh] + [39h]**

[Outline] This command restores the setting saved with ESC 8. If such a command has never been issued, the printer restores the settings as they were at printer power on.

20. ESC = n

Data Input Control

[Code] **[1Bh] + [3D] + n**

[Range] {0 <= n <= FFh}

[Outline] Selecting equipment in which data input from the host is effective.

- Only bit 0 is defined
Value 0: Selected
Value 1: Not selected

- When the printer has not been selected, this printer abandons all the received data until it is selected by this command.

[Caution] • Even when the printer has not been selected, it can become BUSY state through printer operation.

- When the printer is deselected, this printer discards all the data until it is selected with this command.

[Default] The initial value of n is "1".

21. ESC > n

Set Factory Defaults

[Code] **[1Bh] + [3Eh] + n**

[Range] {0 <= n <= FFh}

[Outline] This command writes the current code tables, the intensity level and the current printing speed into the flash memory. These values will be retrieved at first power up or after a power failure.

- Value of n doesn't matter. It is left for compatibility purpose.

[Default] • The initial values are: code tables 0 (US American CP437), intensity level 100%, maximum printing speed.

22. ESC @

Restore saved to nonvolatile RAM settings

[Code] **[1Bh] + [40h]**

[Outline] Clears data stored in the print buffer and brings various settings to the initial state.

[Caution] • Data inside the internal input buffer are not cleared.

- The current code tables, print intensity and printing speed are not reset.
- If switch 5 is OFF, the command clears the downloaded font and bit image too.

[See also] ESC ^ and ESC _

23. ESC D [n] k NUL

Setting Horizontal Tab Position

[Code] **[1Bh] + [44h] + n₁ + ... + n_k + [00h]**

[Range] {0 <= n <= FFh}
{0 <= k <= 20h}.

[Outline] Specifying a horizontal tab position.

- “n” indicates the no. of columns from the beginning to the horizontal tab position. At this time, n= set position 1 is to be specified. For example, to set the position at 9th column, n=8 is to be specified.
- “k” denotes the number of horizontal tab positions you want to set.
- The tab position is set at position where it is “character width x n” from the line beginning. The character width, at this time, includes the right ward space amount. In double wide characters, it is made double of the ordinary case.
- Tab positions can be specified are maximum 32. Specifying exceeding this is ignored.
- <n> k, which denotes a setting position, is input in the increasing order and ends at <00>H.
- ESC D NUL clears all the set tab positions. Following clearing, horizontal tab command is ignored.

[Caution] When the data, <n> k, is equal to or smaller than its preceding data, <n>k-1, it is assumed that tab setting is finished. If this is the case, the next data onward will be processed as normal data. When the data, <n> k, exceeds a 1-line print area, set the horizontal tab position, assuming “Set digit position = Maximum print digits + 1.” The horizontal tab position does not change even if the character width is altered after setting the horizontal tab position.

[Default] Initial value is specified for each eight characters(9 th .17 th .25 th column).

[See Also] HT

24. ESC E n

Specifying/canceling highlighting

[Code] **[1Bh] + [45h] + n**

[Range] {0 <= n <= FFh}

[Outline] Specifying/canceling the highlighting characters.

- “n” is valid only for the lowest bit (n0).
- Control by the lowest bit (n0) is shown as follows:
 - 0 Canceling highlighting.
 - 1 Specifying highlighting.
- This is effective to all characters of font A.
- Characters of font B are not highlighted.
- Dot configuration of a highlighted character includes one extra dot added at its side.

[Caution] The print result of Double printing and highlight character printing is completely same.

[See Also] ESC!

25. ESC G n

Specifying/canceling Double Printing (ESC G n)

[Code] **[1Bh] + [47h] + n**

[Range] {0 <= n <= FFh}

[Outline] Specifying/canceling the double printing.

- “n” is valid only for the lowest bit (n0).
- Control by n is shown as follows.
 - 0 Canceling double printing.
 - 1 Specifying double printing.
- This is effective to all characters of font A.
- Characters of font B are not highlighted.

[Caution] The print result of Double printing and highlight character printing is completely same.

[See Also] ESCE

26. ESC I n

Specifying/cancelling italic printing (ESC I n)

[Code] **[1Bh] + [49h] + n**

[Range] {0 <= n <= FFh}

[Outline] Specifying/canceling the double printing.

- "n" is valid only for the lowest bit (n0).

- Control by n is shown as follows.

0 Canceling italic printing.

1 Specifying italic printing.

27. ESC J n

Printing and feeding paper n/203 inch

[Code] **[1Bh] + [4Ah] + n**

[Range] {0 <= n <= FFh}

[Outline] Prints data inside the print buffer and feeds paper by n/203 inch. Since an actual mechanical pitch is 1/203 inch, it is internally converted approximate to the value specified with this command.

- Specified volume does not remain.
- The beginning of the line is to be considered as the next printing start position.
- Initial value is not defined.

28. ESC M n

Specifying/canceling highlighting

[Code] **[1Bh] + [4Dh] + n**

[Range] {0 <= n <= FFh}

[Outline] Selects character font.

- "n" is valid only for the lowest bit (n0).
- Control by the lowest bit (n0) is shown as follows:

0 Selection of font A (12x24).

1 Selection of font B (9x16).

[Caution] ESC ! can also select fonts, but the setting made by the command processed last is valid.

[See also] ESC!

29. ESC R n

Selecting international character set

[Code] **[1Bh] + [52h] + n**

[Range] {0 <= n <= 10}

[Outline] Depending on the value of „n“, one of the following character sets is selected:

n	Country	Character Set											
		23h	24h	40h	5Bh	5Ch	5Dh	5Eh	60h	7Bh	7Ch	7Dh	7Eh
0	U.S.A.	#	\$	@	[\]	^	`	{		}	~
1	France	#	\$	à	°	é	§	^	`	é	ù	è	~
2	Germany	#	\$	§	Ä	Ö	Ü	^	`	ä	ö	ü	ß
3	U.K.	£	\$	@	[\]	^	`	{		}	~
4	Denmark I	#	\$	@	Æ	Ø	Å	^	`	æ	ø	å	~
5	Sweden	#	\$	È	Ä	Ö	Å	Û	é	ä	ö	å	ü
6	Italy	#	\$	@	°	\	é	^	`	à	ò	è	ì
7	Spain I	Pt	\$	@	ı	Ñ	ı	^	`	ñ		}	~
8	Japan	#	\$	@	[¥]	^	`	{		}	~
9	Norway	#	□	È	Æ	Ø	Å	Û	é	æ	ø	å	ü
10	Denmark II	#	\$	È	Æ	Ø	Å	Û	é	æ	ø	å	ü

30. ESC V n

Specifying/Canceling 90° -right- turned Characters

[Code] **[1Bh] + [56h] + n**

[Range] {0 <= n <= 1}.

[Outline] Specifying/canceling characters 90° -right- turned character.

- "n" means the followings.
 - 0 Canceling 90° -right- turned Characters
 - 1 Specifying 90° -right- turned Characters

[Caution] No underlines are attached to 90e -right- turned characters .

[Default] The initial value of n is "0".

31. ESC X n

Select maximum printing speed

[Code] **[1Bh] + [58h] + n**

[Range] {0 <= n <= 3}
{'0' <= n <= '3'}

[Outline] Selects the maximum printing speed according to the value of 'n':
0 or '0' about 100 mm/s
1 or '1' about 83 mm/s
2 or '2' about 66 mm/s
3 or '3' about 50 mm/s
These values are approximate. The real maximum speed depends on the print intensity and the printing head's temperature.

[Default] The default value is 0 – maximal printing speed.

32. ESC Y n

Selecting the intensity level

[Code] **[1Bh] + [59h] + n**

[Range] {0 <= n <= 5}

[Outline] Set the intensity level.
• "n" means the followings.
0 Set intensity 70 %
1 Set intensity 80 %
2 Set intensity 90 %
3 Set intensity 100 %
4 Set intensity 120 %
5 Set intensity 150 %

[Caution] Higher intensities can cause a lower speed.

[Default] The initial value of n is 3.

33. ESC Z

Transmits identification string.

[Code] **[1Bh] + [5Ah]**

[Outline] The printer transmits 32 bytes of information with the following structure:

1 – 22: Printer name complemented with space up to 22 symbols.
23 – 25: Firmware version – 3 digits (in ASCII format).
26 – 26: Language version – 2 letters.
28 – 32: 5 bytes flags. Each bit describes a printer feature, as '1' means that the feature is present, while '0' means its absence. Bits are described as follows:

Bit	Meaning
28.0	Supports IrDA mode
28.1	Supports magnetic card reader
28.2	Supports simultaneous reading of three tracks from a magnetic card
28.3	ASCII codes above 127 contain Katakana symbols
28.4	Supports JIS and Shift-JIS symbols
28.5	Prints when ESC . and ESC T, and transmits when ESC ' the temperature in ° Fahrenheit
28.6	Not Used
28.7	Reserved – always 1
29.0	Supports downloadable fonts and firmware
29.1	Korean support
29.2	Black mark support
29.3	Bar code reader support
29.4	USB A installed
29.5	USB B installed
29.6	Not Used
29.7	Reserved – always 1
30.0	Not Used
30.1	Not Used
30.2	Not Used
30.3	Not Used
30.4	Not Used
30.5	Not Used
30.6	Not Used
30.7	Reserved – always 1
31.0	Not Used
31.1	Not Used
31.2	Not Used

31.3	Not Used
31.4	Not Used
31.5	Not Used
31.6	Not Used
31.7	Reserved – always 1
32.0	Not Used
32.1	Not Used
32.2	Not Used
32.3	Not Used
32.4	Not Used
32.5	Not Used
32.6	Not Used
32.7	Reserved – always 1

34. ESC \ n1 n2

Specifying the Relative Positions

[Code] **[1Bh] + [5Ch] + n1 + n2**

[Range] {0 <= n1 <= FFh}
{0 <= n2 <= FFh}

[Outline] The printing start position is specified in the number of dots(1/203 inch unit) from the current position.

- Rightward direction is taken as plus and leftward direction as minus.
- To specify N dot in minus (left) direction, use a complement of N for assignment.
– N dots = 65536 – N
- The number of dots is divided by 256, whose quotient is taken as n2 and the residual as n1.
- There are 416 dots per line (positions from 0 to 415) when in “narrow” paper mode
- There are 576 dots per line (positions from 0 to 575) when in “wide” paper mode.

[Caution] Specifying exceeding the beginning of the line or the end of the line is ignored.

[Default] The initial value is not specified.

[See Also] ESC\$

35. ESC _

Restore factory defaults and save them to nonvolatile RAM

[Code] **[1Bh] + [5Fh]**

[Outline] Select font A, no bold, no underline, etc. Restore tab defaults. The parameters are read from the flash memory. Downloaded font and downloaded bit image are cleared. Copy internal fonts A and B to user fonts. DIP switches are read again. Data in the input buffer is not cleared.

[See also] ESC@

36. ESC ‘

Transmits the current power supply voltage and the print head temperature

[Code] <1B>H<60>H

[Outline] The printer transmits two bytes data. First byte is the power supply voltage given as 0.1 mV plus 20h. the second byte is the print head temperature, in degrees Celsius, plus 20h.

[Example] If the battery voltage is 6.4 V, and the print head temperature is 33°C, the printer will transmit <60h><41h>, which is <40h+20h><21h+20h> or <64+32><33+32>.

37. ESC a n

Aligning the characters

[Code] **[1Bh] + [61h] + n**

[Range] {0 <= n <= 2}
{4 <= n <= 6 }

[Outline] This command is extended and has the following format:

All the printed text data, the barcode or the raster bit image (GS v0) within one line are aligned in the specified position. If used before printing a barcode with this command can be specified vertical direction for printing the bar code.

- Depending on n value, positional alignment is carried out as in the table below:

0 Left end alignment

- 1 Centering
- 2 Right end alignment
- 4 Left end aligned vertical bar code
- 5 Centred vertical bar code
- 6 Right end aligned vertical bar code

[Default] The initial value of n is "0".

38. ESC c5 n

Enabling/Disabling Panel Switches

[Code] **[1Bh] + [63h] + [35h] + n**

[Range] {0 <= n <= FFh}

[Outline] Selecting the LF switch valid/invalid.

- "n" is valid only in the lowest bit (n0).
- "n" bit means the followings.
 - 0 LFSW valid.
 - 1 LFSW invalid.

[Caution] When the panel switch is disabled with this command, the LF switch is disabled. Therefore, the paper cannot be fed by operating the LF switch.

[Default] The initial value of n is "0".

39. ESC d n

Printing and Feeding the paper by n lines

[Code] **[1Bh] + [64h] + n**

[Range] {0 <= n <= FFh}

[Outline] Prints data inside the buffer and feeds paper by n lines.

- Specified line does not remain.
- The beginning of the line is to be considered as the next printing start position.

[Default] The initial value is not defined.

40. ESC i

Cutting the paper

[Code] **[1Bh] + [69h]**

[Outline] The command performs a partial cut (one point left uncut). Prior to cutting the paper is fed so the last printed line remains after the cutter's edge.

This command is valid only at the beginning of the line.

41. ESC m

Cutting the paper

[Code] **[1Bh] + [6Dh]**

[Outline] The command is exactly the same as ESC i.

42. ESC p

Generating a drawer-kick pulse

[Code] **[1Bh] + [70h] + m + n1 + n2**

[Range] {0 <= m <= 255}

{0 <= n1 <= 255}

{0 <= n2 <= 255}

[Outline] The value of m is ignored.
The printer generates a 2*n1 milliseconds long pulse and 2*n2 milliseconds long rest after the pulse. n2 must be at least four times greater than n1 or the command will be discarded.

43. ESC t

Selecting the character code table

[Code] **[1Bh] + [74h] + n**

[Range] {0 <= n <= 19}

[Outline] Selects the code table for ASCII codes 80h-FFh.
One of the following supported code tables is selected according to the value of n:

n	Code Table
0	USA (CP437)
1	Litva
2	West Europe Latin I (CP850)
3	Brasil (CP860)
4	Poland
5	Bulgarian (CP856)
6	Central Europe Latin II (CP852)
7	Russian (CP866)
8	Turkish (CP857)
9	Windows English Latin I (CP1252)
10	Baltic (CP775)
11	Latvia
12	Greek (CP737)
13	Hebrew (CP862)
14	Windows Central European Latin II (CP1250)
15	Windows Cyrillic (CP1251)
16	Windows Greek (CP1253)
17	Windows Turkish (CP1254)
18	Windows Hebrew (CP1255)
19	Windows Baltic (CP1257)
20	West Europe Latin I + Euro (CP858)
21	Central Europe Latin II + Euro (CP852 + Euro)
22	Russian + Euro (CP808)
23	Turkish + Euro (CP857 + Euro)

In the **Chinese version** of the printer one of the following supported code tables is selected according to the value of n:

n	Code Table
0	USA (CP437)
1	Chinese GB2312

[Caution] In the international version of the printer when the code page is set by the DIP switches the command is disabled and a code page other than this one cannot be set.
 In the Chinese version of the printer the code table can be changed regardless of the DIP switch setting.
 Code pages 20, 21, 22 and 23 (CP858, CP852 + Euro, CP808 and CP857 + Euro) are not hard-coded code pages, i.e. they do not have the Euro Symbol built in. They are produced by giving the Euro symbol position the proper value. If ESC # is used with some of these pages the Euro symbol position will be changed, i.e. it will not appear twice.
 Even if the code page is set by the DIP switches the command ESC > will store this code page into the flash for further use.
 The command <ESC t 14h> is equal to the combination of commands <ESC t 02h> + <ESC # D5h>.
 The command <ESC t 15h> is equal to the combination of commands <ESC t 06h> + <ESC # AAh>.
 The command <ESC t 16h> is equal to the combination of commands <ESC t 07h> + <ESC # F2h>.
 The command <ESC t 17h> is equal to the combination of commands <ESC t 08h> + <ESC # D5h>.

[Default] The default value is 0 – USA CP437 code page.

44. ESC v

Transmitting the printer status

[Code] **[1Bh] + [76h]**

[Outline] Current printer status is transmitted..

Status sent out consists of 1 byte whose content is as in the table below.

Bit	Function	Value 0	Value 1
0		Not defined	
1		Not defined	
2	Paper end	With paper	Without paper
3	Head temperature	Normal	Overheated
4		Not defined	
5	Auto-cutter	No error	Error (jam)
6		Not defined	
7		Not defined	

45. ESC x n

Reversing the print direction

[Code] **[1Bh] + [78h] + n**

[Outline] This command changes the characters' print direction from left to right to right to left. The character itself is not mirrored horizontally. The command is intended for languages that use right to left scripting, like Hebrew and Arabic.

Only the lowest bit of "n" is valid with the following meaning:

0 – left to right printing

1 – right to left printing

[Caution] The command changes only the print direction of the characters - all graphics and bar codes are unaffected. This command is ignored in the Chinese version of the printer. The command reverses all print attributes of the line and the characters, though the characters themselves are not mirrored horizontally. Though the command allows mixing reversed and non-reversed characters in one line the print results could be unsatisfactory and unreliable.

[Default] The default value is 0 – left to right printing

46. ESC { n

Specifying/Canceling the Inverted Characters

[Code] **[1Bh] + [7Bh] + n**

[Range] {0 <= n <= FFh}

[Outline] Specifying/canceling inverted characters.

- "n" is valid only for the lowest bit (n0).

- Bit n (n0) means the followings.

0 Canceling inverted characters.

1 Specifying inverted characters.

[Caution] • Inverted printing means printing the line at 180° turned.

- Valid is the last value specified in a line.

[Default] The initial value of n is "0".

47. GS (A pL pH n m

Printing a self-test

[Code] **[1Dh] + [28h] + [41h] + pL + pH + n + m**

[Range] {0 <= pL <= 255}

{0 <= pH <= 255}

{0 <= n <= 255}

{2 <= m <= 3}

[Outline] This command is intended for compatibility purposes. A "short" or "long" test is printed depending on the value of m.

m = 2 – printing a "long" test (ESC .)

m = 3 – printing diagnostic information ("short" test) (ESC ,)

48. GS B n

Specifying/canceling the black/white inverted printing

[Code] **[1Dh] + [62h] + n**

According to the least significant bit of n (n0) the following modes are possible:

n0 = 0 – Black/white inverted printing is canceled

n0 = 1 – Black/white inverted printing is specified

The space skipped by tab command or by positioning commands (ESC \$, ESC \) is not affected.

Both built-in and downloaded character sets are inverted by this command.

The black/white inversion works on the right space defined by ESC SP command.

[Default] The initial value is n=0

49. GS L n1 n2

Setting the left margin

[Code] **[1Dh] + [4Ch] + n1 + n2**

[Range] {0 <= n1 <= FFh}

{0 <= n2 <= FFh}

[Outline] Sets the position in dots (1/203 inches) from which each line starts. This command works only if entered at the beginning of the line. The start position is equal to **n1+256*n2** dots from the left end of the printable area.

- [Caution] If a value that exceeds the length of the print area is set the left margin is set to 0.
 $n1+256*n2 < 416$ when a narrow paper is used
 $n1+256*n2 > 576$ when a wide paper is used
- [Default] Default value is 0.

50. (1)GS V m

(2)GS V m n

Cutting the paper

- [Code] (1) $[1Dh] + [56h] + m$
 (2) $[1Dh] + [56h] + m + n$
- [Range] (1) {m=1, m=49}
 (2) {m=66}
 {0 <= n <= 255}
- [Outline] Depending on the value of m one of the following actions is performed:
 - if m=1 or m=49 ('1') a partial cut is performed
 - if m=66 ('B') the paper is fed by n/8 mm and then a partial cut is performed
 In both cases the paper is first fed to the cut position so the last printed line remains after the cutter's edge. This means that in case (2) the paper is fed by "cut position + n/8" millimeters prior to cutting.

51. (1) GS k m [d] k NUL

(2) GS k m n [d] k

(3) GS k m a [d] k NUL

(4) GS k m a xL xH [d] k

Printing the bar code

- [Code] (1) $[1Dh] + [6Bh] + m + D_i + [00h]$
 (2) $[1Dh] + [6Bh] + m + n + D_i$
 (3) $[1Dh] + [6Bh] + m + a + D_i + [00h]$
 (4) $[1Dh] + [6Bh] + m + a + xL + xH + D$
- [Range] (1) {0 <= m <= 6}
 (2) {65 <= m <= 73}
 (3) {m=9; a=0,1}

- (4) {m=74; 256*xH+xL<=3000; a=0,1}
- [Outline] Specifying a type of bar code and printing bar codes.
- The beginning of line is considered as the next printing start position.
 - Depending on the value of m, the following bar code can be selected. **d** indicates a bar code data to be printed and **k** indicates the number of character to be printed.
n indicates number of characters when 65 <= m <= 73.
a is a setting for PDF-417 bar code. Setting **a=0** will make the printer to automatically choose PDF-417 compression modes, while **a=1** will force byte compression mode.
xL and **xH** indicates the number of bytes for PDF-417 bar code when **m=74**. The number of bytes is equal to **256*xH+xL**.
m determines bar code type and it is one of the following:

M(1)	Bar code type	Length	Range of 'd'
0	UPC-A	11	48 <= D _i <= 57
1	UPC-E	11	48 <= D _i <= 57
2	EAN13 (JAN13)	12	48 <= D _i <= 57
3	EAN 8 (JAN8)	7	48 <= D _i <= 57
4	CODE 39	-	48 <= D _i <= 57, 65 <= D _i <= 90, 32, 36, 37, 43, 45, 46, 47
5	ITF	-	48 <= D _i <= 57
6	CODABAR (NW-7)	-	48 <= D _i <= 57, 65 <= D _i <= 68, 36, 43, 45, 46, 47, 58
7	CODE 93	-	1 <= D _i <= 127
8	CODE 128	-	1 <= D _i <= 127
9	PDF-417	-	1 <= D _i <= 255

M(2)	Bar code type	Length	Range of 'd'
65	UPC-A	11	48 <= D _i <= 57
66	UPC-E	11	48 <= D _i <= 57
67	EAN13 (JAN13)	12	48 <= D _i <= 57
68	EAN 8 (JAN8)	7	48 <= D _i <= 57
69	CODE 39	-	48 <= D _i <= 57, 65 <= D _i <= 90, 32, 36, 37, 43, 45, 46, 47
70	ITF	-	48 <= D _i <= 57
71	CODABAR (NW-7)	-	48 <= D _i <= 57, 65 <= D _i <= 68, 36, 43, 45, 46, 47, 58
72	CODE 93	-	0 <= D _i <= 127
73	CODE 128	-	0 <= D _i <= 127
74	PDF-417	-	0 <= D _i <= 255

- [Caution]
- When data being held in the print buffer, this command is ignored.
 - Regardless of the specified feed pitch, this command feeds the paper hat is required to print a bar code.
 - If the character code d cannot be printed in the respective bar code system, the bar code so far will be printed, processing the subsequent data as normal data.
 - When a bar code whose number of characters to be printed is fixed has been selected, the number of characters k have to be always made equal to the number of characters to be printed. (The bar code is not printed when not matching.)
 - When the horizontal direction exceeds one line length, the bar code is not printed.

[Default] •The initial value is not specified.

[CODE 128 additional information]

Code 128 covers all ASCII codes from 0 to 127, and it has three tables A, B and C that can be used in the same bar code.

Table A: contains ASCII symbols with codes 0 to 95 and control symbols FNC1, FNC2, FNC3, FNC4, SHIFT, CODEB, CODEC.

Table B: contains symbols with ASCII codes from 32 to 127 and control characters FNC1, FNC2, FNC3, FNC4, SHIFT, CODEA, CODEC.

Table C: It is used for coding bar code areas that consist only of numerals. Each symbol gives two digits that are coded with ASCII codes from 0 to 99. Control characters FNC1, CODEA, CODEB are also available.

The bar code must start with one of the symbols CODEA, CODEB or CODEC, that determines which table will be used. If it is necessary the current table could be changed later by inserting one of these symbols in to the bar code. The symbol following SHIFT character is considered to be from table B, if table A is current, or from table A, if table B is current. If a symbol that is not valid for the current table is used, the whole bar code is not printed.

Control symbols are assigned two bytes as follows:

Symbol	Code system		
	Decimal	Hexadecimal	Text
FNC1	123, 49	7B, 31	{1
FNC2	123, 50	7B, 32	{2
FNC3	123, 51	7B, 33	{3
FNC4	123, 52	7B, 34	{4

CODEA	123, 65	7B, 41	{A
CODEB	123, 66	7B, 42	{B
CODEC	123, 67	7B, 43	{C
SHIFT	123, 83	7B, 53	{S
{	123, 123	7B, 7B	{{

52. GS w n

Selecting the horizontal size (Scale factor) of the bar code

[Code] **[1Dh] + [77h] + n**

[Range] {2 <= n <= 4}

[Outline] Selecting bar code width.
n denotes the number of dots in fine element width.

[Default] The initial value of this width is "3"

53. GS h n

Selecting the height of the Bar Code

[Code] **[1Dh] + [68h] + n**

[Range] {1 <= n <= FFh}

[Outline] Selecting bar code height.
n denotes the number of dots in the vertical direction.

[Default] The initial value of n is "162"

54. GS H n

Selecting of Printing Position of HRI Code

[Code] **[1Dh] + [48h] + n**

[Range] {0 <= n <= 3}

[Outline] Selecting printing position of HRI code in printing bar codes.

- "n" means the followings.

- 0 No printing
- 1 Above the bar code
- 2 Below the bar code

3 Both above and below the bar code

The HRI code refers to the bar code-turned characters so that you can read them.

[Caution] The HRI code is printed in the font selected with GS f. Specify before the GS k command.

[Default] The initial value of n is "0".

[See Also] GS f

55. GS f n

Selecting the font of HRI code

[Code] **[1Dh] + [66h] + n**

[Range] n = 0, 1

[Outline] Selecting the font of HRI code in printing bar code.
The type of font can be printed by selecting n is as follows.

0 Font A

1 Font B

The HRI code refers to the bar code-turned characters so that you can read them.

[Caution] The HRI code is printed at the position specified with GS h on page 63.

[Default] The initial value of n is "0".

[See Also] GSH

56. GS p n1 n2 n3

Setting bar code PDF-417 parameters

[Code] **[1Dh] + [70h] + n1 + n2 + n3**

[Range] {0 <= n1 <= 255}

{0 <= n2 <= 30}

{n3=0; 3 <= n3 <= 90}

[Outline] **n1** selects PDF-417 security level. Setting a security level higher than eight forces the printer to automatically adjust the security level according the following table:

EC level	EC Codewords	Auto Select Level
0	2	-
1	4	0-31
2	8	32-63
3	16	64-127
4	32	128-255
5	64	256-511
6	128	512-928
7	256	-
8	512	-

- Only real data codewords in the security level calculation (any pad codewords are ignored).

n2 – number of data columns. If **n2=0** the number of data columns is automatically calculated.

n3 – number of rows. If **n3=0** the number of rows is automatically calculated.

[Caution] If any value is out of range this value remains unchanged. Thus the other values are changed.

[Default] The initial value of n1 is "9" (auto select).
The initial value of n2 is "0" (auto select).
The initial value of n3 is "0" (auto select).

[See Also] GS k

57. GS v0

Printing of raster bit image

[Code] **[1Dh] + [76h] + [30h] + m + xL + xH + yL + yH + D₁ + ... + D_n**

[Range] {0 <= m <= 3; 48 <= m <= 51}

{0 <= xL <= 255}

{0 <= xH <= 255}

{0 <= yL <= 255}

{0 <= yH <= 255}

{0 <= D_i <= 255}

[Outline] The value of **xH** is ignored.
Although **yH** could be from 0 to 255 the high four bits are ignored, so **yH** could actually be from 0 to 15.

xL is the number of bytes in horizontal direction (xL*8 dots).
 The number of dots in horizontal direction is equal to yL+yH*256.
 The number of data bytes **k**=xL * (yL+yH*256). However k must not be equal to 0 or the bit image will be discarded.
m defines the printing mode of the bit image according to the following table:

m	Mode	Dot density in vertical direction	Dot density in horizontal direction
0	Normal	203 DPI	203 DPI
1	Double width	203 DPI	101 DPI
2	Double height	101 DPI	203 DPI
3	Quadruple	101 DPI	101 DPI

The bit image is defined line by line from left to right. The most significant bit of each byte is the leftmost dot and the least significant bit is rightmost dot.

The data that exceeds the printing width of the line is discarded.
 The raster bit image could be positioned using the commands ESC \, ESC \$ and GS L.

The raster bit image could be justified using the ESC a command.

If this command is executed during a macro definition, the macro definition is finished and the command is executed.

58. GS *

Defining the Download Bit Image

There are two variants of this command depending of the position of switch 5.

If switch 5 is OFF:

[Code] **[1Dh] + [2Ah] + n1 + n2 + D₁ + ... + D_n**

[Range] {0 <= n1 <= 255}
 {0 <= n2 <= 34}
 {0 <= D_i <= 255}

[Outline] **n1** denotes the horizontal size of the bit image
n2 denotes the vertical size of the bit image
 There are **n1*n2*8** bytes of data in order from top to bottom and from left to right, n1 bytes in each vertical column of dots.

This command defines a bit image with number of dots determined by **n1** and **n2**. There are n1*8 dots in horizontal direction and n2*8 number of dots in vertical direction.

If **n1** is 0 the downloaded bit image is cleared.

The command GS / is used to print downloaded bit image.

If switch 5 is ON:

[Code] **[1Dh] + [2Ah] + n1 + n2 { + n21 + n22 } + D₁ + ... + D_N**

[Range] {0 <= n1 <= 7Fh}
 {0 <= n2 <= F8h}
 {0 <= D_i <= FFh}
 {1 <= n21+256*n22 <= 272}

[Outline] If **n2** is 0 two more bytes are read. These two bytes then determine the vertical size of the bit image. The vertical size then is N= n21+256*n22 rows.

If **N** is the vertical size of the bit image, N=n2 or N= n21+256*n22.

D_i is the bit image's data. The number of data bytes is n1*N. There are n1 bytes in the first row then n1 bytes in the second, etc. There are N rows in the bit image, and the number of dots in the bit image is n1*N*8. Each data bit defines one dot, value of "1" corresponds to black.

If **n1** is 0 the downloaded bit image is cleared.

The downloaded bit image remains effective even if the printer is switched off.

[See Also] GS /

59. GS / m

Printing the Download, Bit Image

[Code] **[1Dh] + [2Fh] + m**

[Range] {0 <= m <= 3}

[Outline] Prints download bit image in a mode specified by m.

m	Mode Name	Dots in Vertical Direction	Dots in Horizontal Direction
0	Normal mode	203 DPI	203 DPI
1	Double wide mode	203 DPI	101 DPI
2	Double high mode	101 DPI	203 DPI
3	DW / DH mode	101 DPI	101 DPI

- [Caution]
 - When data exist inside the print buffer, this command is ignored.
 - When a download bit image has not been defined, this command is ignored.
 - A portion of a download bit image exceeding one line length is not printed.
- [Default] The initial value is not specified.
- [See Also] GS *

60. GS :

Starting / Ending Macro Definition

- [Code] **[1Dh] + [3Ah]**
- [Outline] Specifying starting / ending macro definition. Means termination when received while defining a macro.
- [Caution] Maximum content available for macro definition is 3823 bytes. A portion exceeding 3823 bytes is not defined.
 - Even with ESC @ (initialization of the printer) having been executed, defined content is not cleared. Therefore, it is possible to include ESC @ into the content of macro definition.
 - Normal printing operation is carried out even while in macro definition
- [Default] Initially, Macro is not specified.
- [See Also] GS ^

61. GS ^ n1 n2 n3

Executing the Macro

- [Code] **[1Dh] + [5Eh] + n1 + n2 + n3**
- [Range]
 - {0 <= n1 <= FFh}
 - {0 <= n2 <= FFh}
 - {0 <= 3 <= 1}.
- [Outline] Executing contents defined in macro.
 - “n1~n3” indicate as follows:
 - n1** : The number of times of macro execution
 - n2** : Waiting time on macro execution
 Waiting time of n2 x 100 milliseconds is given for every execution.
 - n3** : Macro execution mode

- 0 Continuous execution
 - 1 Execution by LFSW
- Continuous execution:** The Macro is executed n1 times continuously at the time intervals specified by n2.
- Execution by FEEDS:** After waiting for lapse of time specified by n2, the LF switch is waited to be pressed. When it is pressed, the macro is executed once. This action is repeated n1 times.
- [Caution]
 - When this command is received while in macro definition, suspension of macro definition is indicated. At this time, the defined content is cleared.
 - No execution takes place when macro is held undefined or n1=0.
 - While in macro execution with n3=1, paper feed with the LF SW is not available.
- [Default]
 - Initially, this command is not specified.
- [See Also] GS :

62. FS p n m

Printing the downloaded NV bit image

- [Code] **[1Ch] + [70h] + n + m**
- [Range]
 - {0 <= n <= FFh}
 - {0 <= m <= 3}
 - {48 <= m <= 51}
- [Outline] Printing the downloaded NV bit image defined by FS q command.

m	Mode Name	Dots in Vertical Direction	Dots in Horizontal Direction
0, 48	Normal mode	203DPI	203DPI
1, 49	Double wide mode	203DPI	101DPI
2, 50	Double high mode	101DPI	203DPI
3, 51	DW/DH mode	101DPI	101DPI

“n” is discarded - the printer supports only one NV bit image.
“m” is the bit image printing mode.

63. FS q n [xL xH yL yH D1 D2 ... Dk]

Defining the downloaded NV bit image

There are two variants of this command depending of the position of switch 5.

If switch 5 is OFF:

- [Code] **[1Ch] + [71h] + n + xL + xH + yL + yH + D1 + D2 + ... + Dk**
- [Range] {0 <= n <= FFh}
 {0 <= xL <= FFh}
 {0 <= xH <= FFh}
 {0 <= yL <= FFh}
 {0 <= yH <= FFh}
 {0 <= D <= FFh}
- [Outline] This command defines the specified NV (non volatile) bit image. The bit image is stored into the flash.
 "n" is ignored – the printer supports only one bit image.
 xL and xH denote the horizontal size of the NV bit image as (xL + xH x 256) x 8 dots.
 yL and yH denote the vertical size of the NV bit image as (yL + yH x 256) x 8 dots.
 Total amount of data defining the bit image is (xL + xH x 256) x (yL + yH x 256) x 8 bytes.
- [Details] The maximum printable size of the NV bit image is 576 x 512 dots. This corresponds to (xL + xH x 256) < 76 and (yL + yH x 256) < 64.
 The exceeding data is read but discarded.
 The order of the data is from top to bottom and then from left to right, (yL + yH x 256) bytes in each vertical column of dots.
 The printer will become busy before each writing cycle in the NV memory. Any data sent while the printer is busy may not be processed and therefore could be lost.
 xL = xH = yL = yH = 0 clears the downloaded bit image.

If switch 5 is ON:

- [Code] **[1Ch] + [71h] + n + xL + xH + yL + yH + D1 + D2 + ... + Dk**
- [Range] {0 <= n <= FFh}
 {0 <= xL <= FFh}

- {0 <= xH <= FFh}
 {0 <= yL <= FFh}
 {0 <= yH <= FFh}
 {0 <= D <= FFh}

- [Outline] This command defines the specified NV (non volatile) bit image. The bit image is stored into the flash.
 "n" is ignored – the printer supports only one bit image.
 xL and xH denote the horizontal size of the NV bit image as (xL + xH x 256) x 8 dots.
 yL and yH denote the vertical size of the NV bit image as (yL + yH x 256) dots.
 Total amount of data defining the bit image is (xL + xH x 256) x (yL + yH x 256) bytes.
- [Details] The maximum printable size of the NV bit image is 576 x 512 dots. This corresponds to (xL + xH x 256) < 76 and (yL + yH x 256) < 512.
 The exceeding data is read but discarded.
 The order of the data is from left to right and then from top to bottom, (xL + xH x 256) bytes in each horizontal row of dots.
 The printer will become busy before each writing cycle in the NV memory. Any data sent while the printer is busy may not be processed and therefore could be lost.
 xL = xH = yL = yH = 0 clears the downloaded bit image.